



Recorder



Flow



Pressure



Temp



Analyzer



Level

Datasheet

Vortex Flowmeter

SUP-LUGB-C

Supmea[®]

Committed to process automation solutions

Tel: 86-15158063876

E-mail: info@supmea.com

www.supmea.com

Datasheet**Vortex Flowmeter
SUP-LUGB-C**

The SUP-LUGB vortex flow meter is a kind of velocity flow meter, which is designed based on the research and design of the Karman vortex principle. It is mainly used for flow measurement of medium fluid in industrial pipelines, such as gas, steam, or liquid, and other media. Flow control and metering. The LUGB vortex flow meter can realize the following functions according to different types: measure the temperature, pressure, instantaneous flow, and cumulative flow of the industrial pipeline medium fluid, and has pulse output, (4~20)mA analog signal output, RS485 communication (Modbus RTU protocol), IoT GPRS and other functions.

Applications

- Energy industry
- Chemical industry
- Environmental Industry
- Metallurgy
- Textile
- Steel
- Pharmaceutical
- Paper-making

**Features**

- Ability to measure flow accurately and reliably.
- The main body of the product has no moving parts, high reliability, long-term stability, simple structure and easy maintenance;
- The output of the sensor is pulse frequency, its frequency is linear with the actual flow rate of the measured fluid, the zero point has no drift, and the performance is very stable.
- Various structural forms, including pipeline type, insertion type flow sensor and other forms;
- High accuracy, the measurement accuracy of conventional liquid is $\pm 1.0\%$; the measurement accuracy of gas is $\pm 1.5\%$;
- The pressure loss is small (about 1/4~1/2 of the

Vortex Flowmeter

orifice flow meter), which belongs to the energy-saving flow meter;

- The installation method is flexible, and it can be installed horizontally, vertically or inclined at different angles according to the different process pipelines on site;
- The circuit adopts multiple protection modes, anti-surge and strong adaptability;
- The high-precision probe adopts the piezoelectric wafer vortex sensor, and the signal is stable.

Principle

The vortex flow meter is a velocity flow meter produced according to the Karman vortex principle, which can be used for the measurement and metering of conventional gases, steam, and liquids. The vortex flow meter has high precision and a wide range ratio, and there are no moving parts in use, which can improve mechanical stability and reduce maintenance. The vortex street is almost not affected by the temperature, pressure, and composition of the medium when measuring the volume of the working condition, so it is convenient for the calibration and production of the instrument, so the vortex flow meter is widely used in production and life.

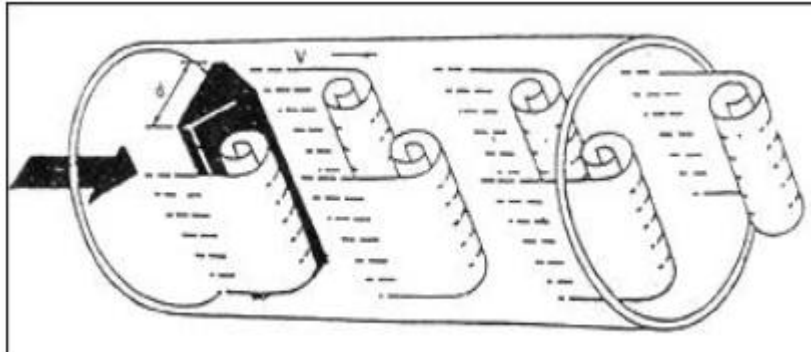

If a triangular column-type vortex generator is set in the fluid, regular vortices are generated alternately from both sides of the vortex generator. This kind of vortex is called the Karman vortex, and the vortex columns are arranged asymmetrically downstream of the vortex generator. The vortex street is produced according to this principle. The vortex is generated by the generator, and the high-sensitivity sensor detects the number of vortices. The number of vortices generated within a certain range is proportional to the flow rate, so the flow rate can be calculated by a precision processor.

In a vortex flow meter, the relationship between the flow rate and the number of vortices generated can be the following formula:

$$Q = \frac{3600f}{K}$$

Q: The working condition volume flow of the measured medium, the company uses m³/h as the unit.

f: The frequency of the number of vortices generated by the generator, the company uses Hz as the unit.

K: Refers to the calculated or calibrated flow coefficient, which represents how many frequency signals there are per cubic meter. This coefficient is generally obtained by calibration.

Standard table method calibration coefficient K formula:

$$K = \frac{\text{Checked meter flow } Q_C}{\text{Standard meter flow } Q_S} \times K_{\text{Coefficient of the checked meter}}$$

(this formula can also be used for flow correction)

Parameters	
Basic Parameters	
Items	Main parameters
Nominal diameter (mm)	15, 20, 25, 32, 40, 50, 65, 80, 100, 125, 150, 200, 250, 300, 300-1000 (plug-in)
Pressure Resistance	Flange clamp installation: DN15~DN50, pressure 4.0MPa; DN65~DN100, withstand pressure 2.5MPa Above DN125, pressure resistance 1.6MPa Flange connection: DN15~DN50, pressure resistance 2.5MPa; DN65~DN300, withstand pressure 1.6MPa
Conditions of Use	Medium temperature: normal temperature type: (-40~100)°C; medium temperature type: (-40~250)°C; high temperature type: (-40~330)°C Ambient temperature: (-20~55)°C Relative humidity: 5% to 90% Atmospheric pressure: (86~106)kPa
Material	Body: 304 Totalizer housing: Die-cast aluminum
Allowable vibration acceleration	Piezoelectric: 0.2g
Accuracy	Flow: ±1.0%, ±1.5%; plug-in type: ±2.5%R Temperature: ±0.8°C Pressure: ±0.3%FS
Turndown ratio	1:10~1:25
Supply voltage	Sensor: DC +24V Transmitter: DC +24V Battery powered type: 3.6V battery
Output signal	Pulse output, (4~20)mA current, RS485 Modbus-RTU protocol)
Pressure loss coefficient	Conform to JB/T9249 standard Cd≤2.4
Protection grade	IP65
Electrical Interface	M20*1.5 Cable Gland or NPT1/2 Cable Gland

Applicable medium	Gas, liquid, steam				
Transmission distance	Three-wire pulse output type: ≤300m; Two-wire standard current output type (4~20) mA: ≤1500m, load resistance ≤500Ω; RS485: ≤1200m.				
Vortex Accuracy Grade					
Accuracy grade		1	1.5	2	2.5
Maximum influence error	$q_t \leq q < q_{max}$	±1.0%	±1.5%	±2.0%	±2.5%
	$q_{min} \leq q < q_t$	±2.0%	±3.0%	±4.0%	±5.0%
Note: The boundary flow refers to 0.2q _{max}					

Size (mm)	Liquid		Gas		Expand scope (m³/h)
	Measuring range (m³/h)	Output frequency range (Hz)	Measuring range (m³/h)	Output frequency range (Hz)	
15	0.5~5	35~600	3~10	300~1240	3~13
20	0.6~10	29~420	6~24	220~1250	6~30
25	1.2~16	21~210	9~48	190~1140	8.8~52
32	1.8~20	18~264	10~100	156~1080	10~170
40	2~40	10~200	27~150	140~1040	27~205
50	3~60	8~160	40~320	94~1020	35~380
65	4~85	6~120	60~480	94~910	60~700
80	6.5~130	4.1~82	90~720	55~690	86~1100
100	15~220	4.7~69	150~1050	42~536	133~1700
125	20~350	3.2~57	200~2200	38~475	150~2800
150	30~450	2.8~43	350~2500	33~380	347~4000
200	45~800	2~31	600~4000	22~315	560~8000
250	65~1250	1.5~25	900~7000	18~221	890~11000
300	95~2000	1.2~24	1400~11000	16~213	1360~18000
(300)	100~1500	5.5~87	1560~15600	85~880	/
(400)	180~3000	5.5~87	2750~27000	85~880	/
(500)	300~4500	5.5~87	4300~43000	85~880	/
(600)	450~6500	5.5~88	6100~61000	85~880	/
(800)	750~10000	5.5~88	11000~110000	85~880	/
(1000)	1200~17000	5.8~88	17000~170000	85~880	/

Note:

The measuring flow range of different caliber meters will be different. In the process of meter selection, the meter must be selected according to the flow range. The most taboo is to choose the meter according to the thickness of the pipe. The biggest disadvantage of choosing an instrument according to the pipeline is that it is easy to cause measurement errors due to insufficient flow.

The flow range of the vortex flow meter is determined based on the flow rate of the working condition, so the flow rate is converted into the flow rate of the working condition when selecting the meter, and then compared with the flow range table, the common flow rate should be in the middle range of the meter measurement as much as possible.

Reference conditions:

Gas: Air at normal temperature and pressure, $t=20^{\circ}\text{C}$, $P=101.32\text{kPa}$ (absolute pressure), $\rho=1.205\text{ kg/m}^3$.

Liquid: normal temperature water, $t=20^{\circ}\text{C}$, $\rho=998.2\text{kg/m}^3$.

Working condition flow refers to the volume of the medium passing through the pipeline measured by the instrument, which is the medium under working conditions. For example, gas can be compressed. When there is pressure in the pipeline, the compressed volume of the gas is the working condition flow. The working condition flow will change as the working environment changes.

Standard condition flow refers to the volume of the medium under standard atmospheric pressure and 0°C (or 20°C) standard, when the compressed gas is released into the standard condition environment, the converted volume. The standard flow will not change in any environment.

The volume measured by the vortex flow meter is the working condition volume, and the standard condition volume can only be obtained after temperature and pressure compensation. Generally, when it is used for trade measurement, the standard condition is mainly used for gas, and the mass measurement is usually used for steam.

Dimension

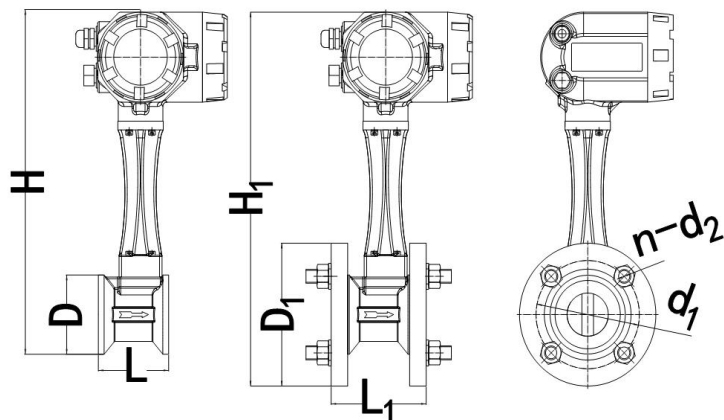

Flange and clamp connection fig. 1

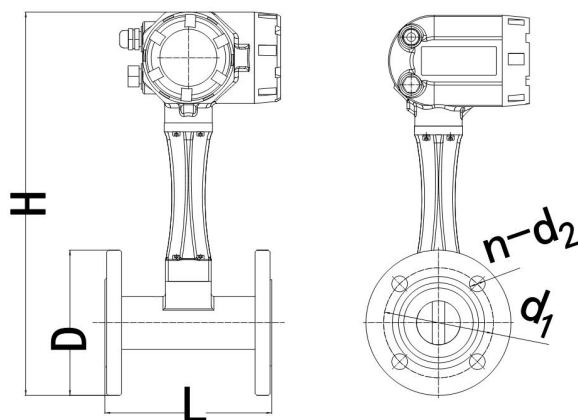

Flange connection fig. 2

Flange and clamp connection ordinary on-site display dimensions table 1

Size	Pressure MPa	Common L(mm)	Common L ₁ (mm)	D mm	D ₁ mm	H mm	H ₁ mm	d ₁ mm	d ₂ mm	n Number of holes
DN15	0~4.0	70	95	55	100	366	393	78	14	3
DN20		70	95	55	100	366	393	78	14	3
DN25		70	95	55	100	366	393	78	14	3
DN32		70	95	55	100	366	393	78	14	3
DN40		85	113	80	140	378	405	105	18	4
DN50		85	113	90	145	387	418	115	18	4
DN65	0~1.6	85	113	105	165	402	438	130	18	4
DN80		85	113	120	180	417	453	145	18	6

DN100	85	113	140	210	437	478	175	18	6
DN125	85	119	165	235	462	503	200	18	8
DN150	100	132	194	270	489	533	230	22	8
DN200	100	132	248	325	541	588	285	22	8
DN250	115	151	300	375	592	638	330	24	10
DN300	130	166	350	425	642	688	380	24	10

Note:

① The above dimensions are clamped without temperature and pressure compensation, the error is $\pm 2\text{mm}$, and the length L/L1 of the temperature and pressure compensation size DN15-DN32 is increased by 15mm;

② Medium and high temperature ($\geq 100^\circ\text{C}$), the height is increased by 30mm (one heat sink).

Flange connection ordinary on-site display dimensions table 2

Size mm	Pressure MPa	L (mm)	D (mm)	H (mm)	d1 (mm)	d2 (mm)	n Number of holes
DN10	0~4.0	170	90	395	60	14	4
DN15		170	95	397	65	14	4
DN20		170	105	402	75	14	4
DN25		170	115	407	85	14	4
DN32		170	140	420	100	18	4
DN40		170	150	425	110	18	4
DN50		170	165	432	125	18	4
DN65	0~1.6	190	185	455	145	18	8
DN80		190	200	470	160	18	8
DN100		200	220	490	180	18	8
DN125		200	250	520	210	18	8
DN150		200	285	550	240	22	8
DN200		200	340	605	295	22	12
DN250		240	405	665	355	26	12
DN300	240	460	715	410	26	12	

Note: For medium and high temperature ($\geq 100^\circ\text{C}$), the height should be increased by 30mm (one heat sink).

Ordering code

SUP-LUGB-C -15-U1-A-M-0-K0-T1-WG									Description
SUP-LUGB-C	-	-	-	-	-	-	-	-	
Nominal Diameter	15								DN15(1/2")
	20								DN20(3/4")
	25								DN25(1")
	32								DN32(1.25")
	40								DN40(1.5")
	50								DN50(2")
	65								DN65(2.5")
	80								DN80(3")
	1C								DN100(4")
	1E								DN125(5")
	1G								DN150(6")
	2C								DN200(8")
	2G								DN250(10")
	3C								DN300(12")
Process Connection and Body Material	U1								Carbon Steel Clamping Flange, 304SS
	U2								304SS Clamping Flange, 304SS
	HA								HG/T20592 Flange Connection, 304SS
	IA								ISO2852 clamp, 304SS
	IC								ANSI B16.5 Flange Class 150, 304SS
	ID								ANSI B16.5 Flange Class 300, 304SS
	IE								ANSI B16.5 Flange Class 600, 304SS
	IF								JIS B2220 Flange 10K, 304SS
	IG								JIS B2220 Flange 20K, 304SS
	XX								Others
Measured Medium	A								Steam
	B								Gas
	C								Liquid

Accuracy	M				1.5 Class
	L				1.0 Class
Compensation Method	0				Standard Structure without Compensation
	1				Temperature and Pressure Compensation
	2				Temperature Compensation
	3				Pressure Compensation
Output, Display, and Power Supply	K0				Pulse, No Display, 24VDC
	K3				Pulse + Two-Wire 4-20mA, Display, 24VDC
	K4				Pulse + Two-Wire 4-20mA, Display, 24VDC + Battery Dual Power Supply
	K5				Pulse + Three-Wire 4-20mA + RS485, Display, 24VDC
	K6				Pulse + Two-Wire 4-20mA + HART, Display, 24VDC
	R1				RS485, Display, 24VDC
	XX				Others
Temperature Resistance	T1				-40-100°C
	T4				-40-250°C
	TR				-40-330°C
	XX				Others
Electrical Interface, Housing Material, and Protection Rating	WG				M20*1.5 Cable Gland, Aluminum Alloy, IP65
	WJ				NPT1/2 Cable Gland, Aluminum Alloy, IP65